

## HPF III 630 SALZ

Hydraulische Doppeldruckpresse  
*Hydraulic double pressure press*

### Maschinendaten *Machine specifications*

Gesamtgewicht ohne Zusatzausrüstung und Zubehör <i>Total weight without additional equipment or accessories</i>	<b>31.000 kg</b>
Presskraft <i>Press power</i>	<b>6.300 kN</b>
Ausstoßkraft <i>Ejection power</i>	<b>1.600 kN</b>
Max. Pressleistung <i>Max. capacity</i>	<b>4,0 Hübe/min 4,0 strokes/min</b>
Füllhöhe <i>Filling depth</i>	<b>500 mm</b>
Betriebshochdruck <i>Max. operating pressure</i>	<b>320 bar (32 MPa)</b>



### Installationsangaben *Installation data*

Max. Einzellast für die Montage – komplettes Pressengestell <i>Heaviest component during assembly – complete press body</i>	<b>22.000 kg</b>
Elektrischer Anschlusswert bei 50 Hz <i>Total connected electric load at 50 Hz</i>	<b>105 kW</b>
Kühlwasserbedarf bei 25 °C – Kühlwasser-Eingangstemperatur ca. <i>Cooling water consumption at a water entrance temperature of 25 °C, approx.</i>	<b>2,0 – 4,0 m³/h</b>
Pressluftverbrauch bei 5 bar (0,5 MPa) Mindestluftdruck ca. <i>Compressed air consumption at a minimum pressure of 5 bar (0,5 MPa), approx.</i>	<b>30 l/min</b>
Hydraulikölmenge für eine Systemfüllung ca. <i>Hydraulic oil for one oil fill, approx.</i>	<b>1.600 l</b>

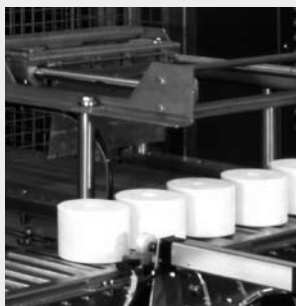
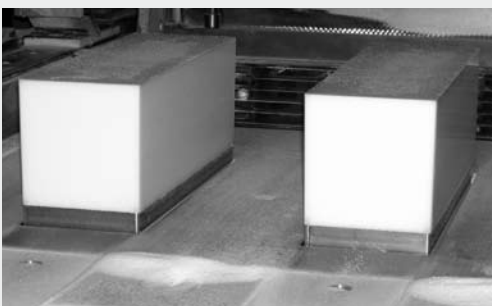

# LAEIS

## Abmessungen Dimensions

## HPF III 630 SALZ

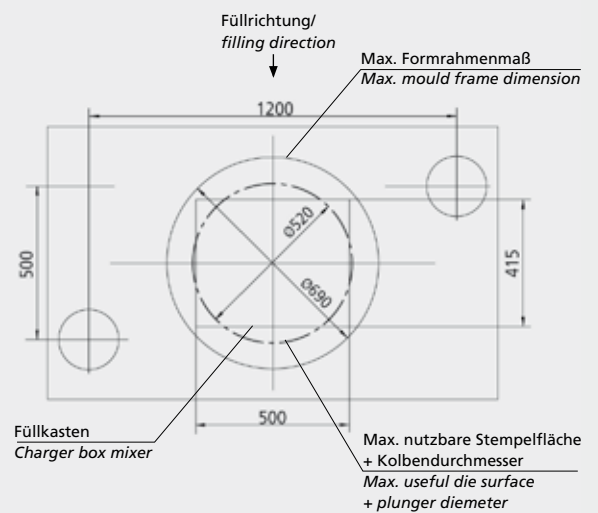
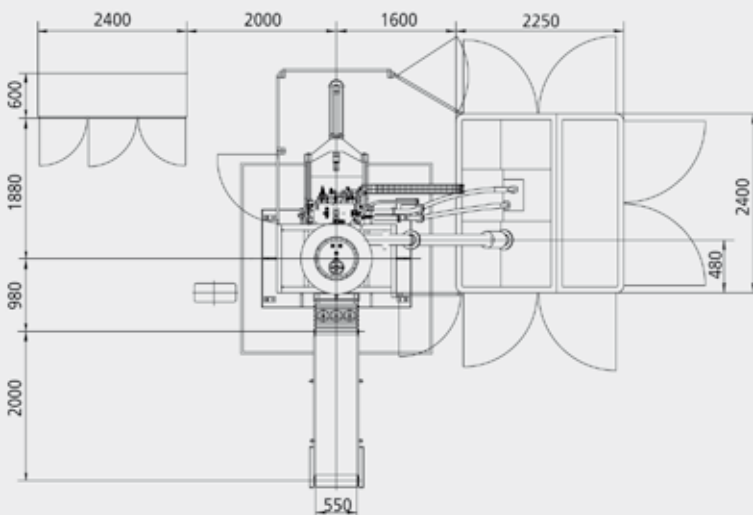
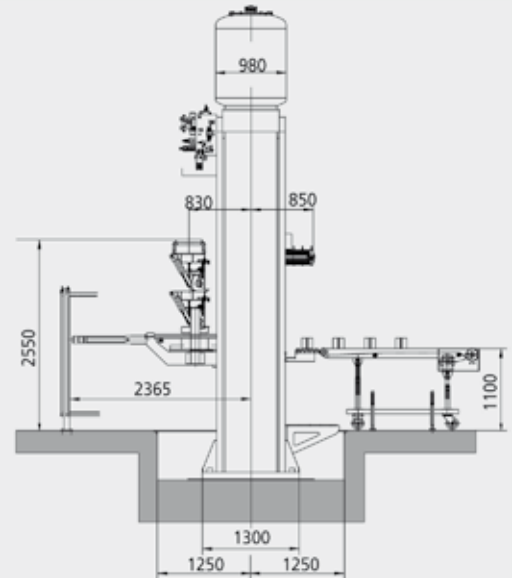
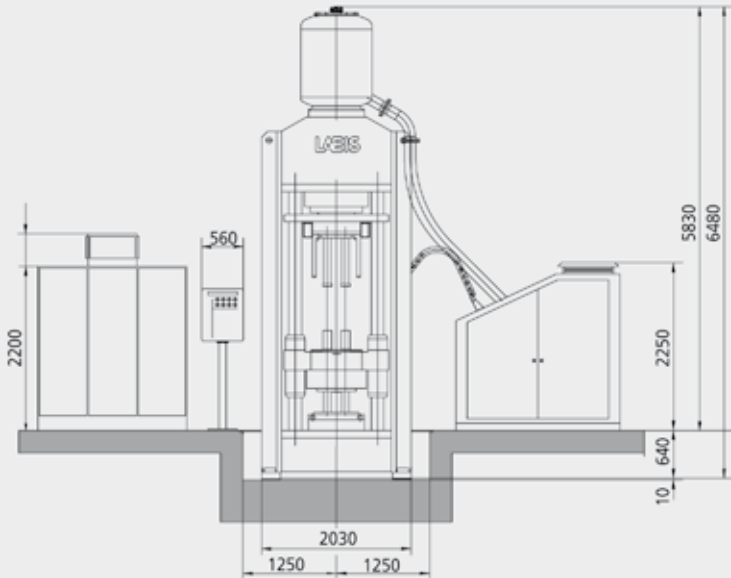

Version: 12.10.2009  
Technische Änderungen vorbehalten.  
Subject to technical modifications.

[WWW.LAEIS.EU](http://WWW.LAEIS.EU)

LAEIS GmbH  
Am Scheerleck 7  
L-6868 Wecker  
Luxemburg  
Phone +352 27612 0  
Fax +352 27612 109  
info@laeis.eu

a company of  SACMI

**LAEIS**