

HPF IV 2500

Hydraulische Doppeldruckpresse
Hydraulic double pressure press

Maschinendaten *Machine specifications*

Gesamtgewicht ohne Zusatzausrüstung und Zubehör <i>Total weight without additional equipment or accessories</i>	120.000 kg
Presskraft <i>Press power</i>	25.000 kN
Ausstoßkraft <i>Ejection power</i>	2.500 kN
Max. Pressleistung <i>Max. capacity</i>	4,5 Hübe/min <i>4,5 strokes/min</i>
Füllhöhe <i>Filling depth</i>	600 mm
Betriebshochdruck <i>Max. operating pressure</i>	320 bar (32 MPa)



Installationsangaben *Installation data*

Max. Einzellast für die Montage – komplettes Pressengestell Presszylinder mit Kolben und Ventilblock <i>Heaviest component during assembly – complete press body</i> Press cylinder with plunger and valve block	110.000 kg 48.000 kg
Elektrischer Anschlusswert bei 50 Hz <i>Total connected electric load at 50 Hz</i>	215 kW
Kühlwasserbedarf bei 25 °C – Kühlwasser-Eingangstemperatur ca. <i>Cooling water consumption at a water entrance temperature of 25 °C, approx.</i>	3,0 – 6,0 m³/h
Pressluftverbrauch bei 5 bar (0,5 MPa) Mindestluftdruck ca. <i>Compressed air consumption at a minimum pressure of 5 bar (0,5 MPa), approx.</i>	30 l/min
Hydraulikölmenge für eine Systemfüllung ca. <i>Hydraulic oil for one oil fill, approx.</i>	3.000 l

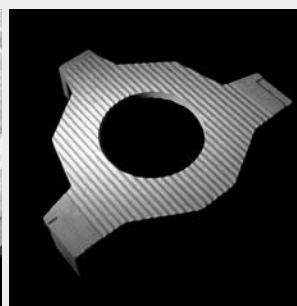
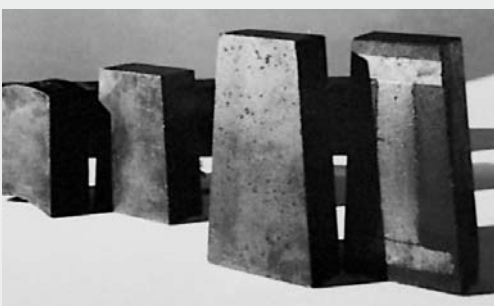

LAEIS

Abmessungen Dimensions

HPF IV 2500

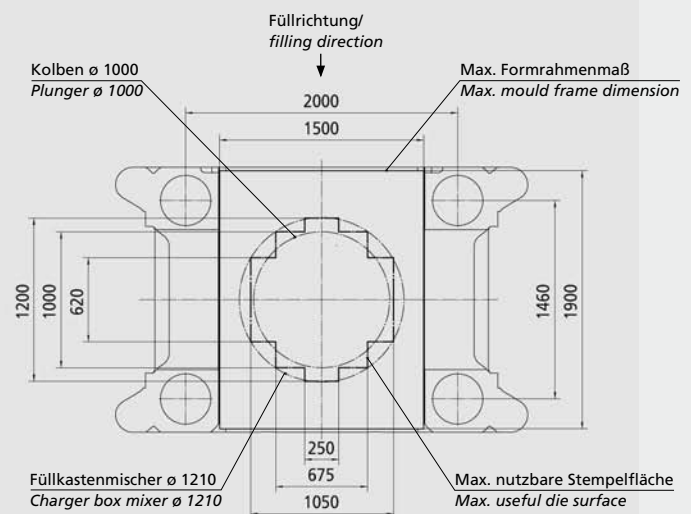
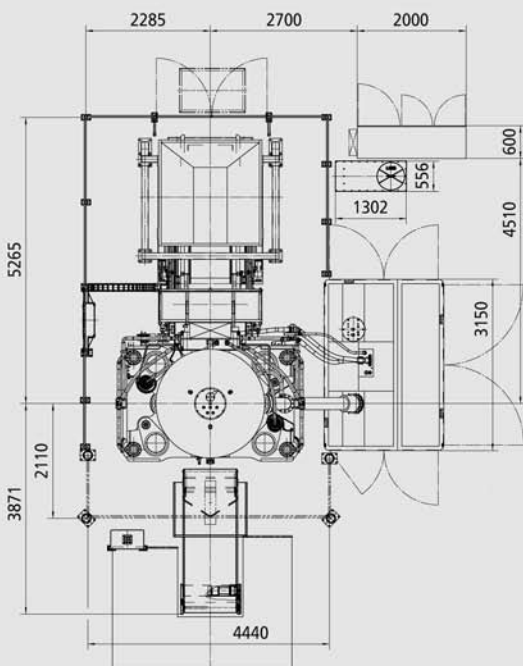
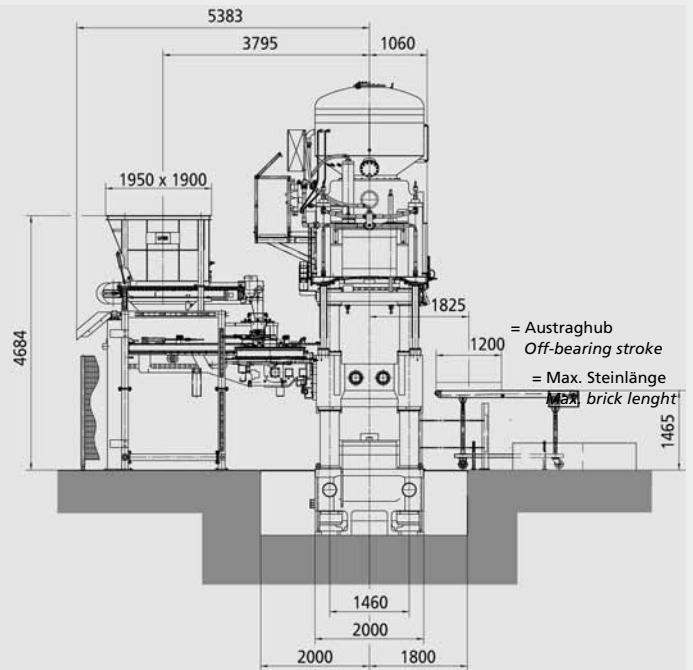
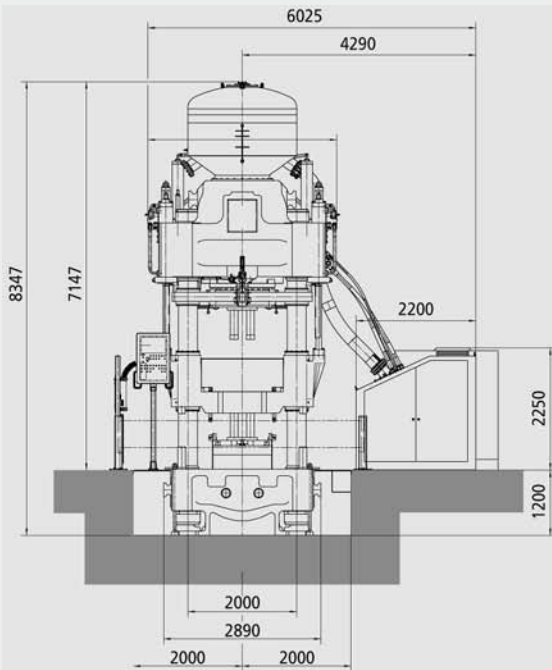

Version: 13.01.2011
Technische Änderungen vorbehalten.
Subject to technical modifications.

WWW.LAEIS.EU

LAEIS GmbH
Am Scheerleck 7
L-6868 Wecker
Luxemburg
Phone +352 27612 0
Fax +352 27612 109
info@laeis.eu

a company of  SACMI

LAEIS